

Italia by **DOMINIONI**
GROUP



P A S T A M A C H I N E



Italia

T H E N E W I T A L I A N P A S T A S T Y L E

ITA Dall'esperienza della Dominioni Group è nata Italia, la nuova macchina per pasta fresca multifunzione brevettata pensata per ristoranti e alberghi, capace di produrre in automatico, grazie ad accessori extra speciali ad innesto:

- . 400 tipi di pasta corta e lunga estrusa trafiletata al bronzo o al teflon
- . pasta laminata a spessore regolabile liscia o ruvida
- . pasta lunga piatta
- . ravioli con ripieno morbido, cremoso o a pezzi con la particolarità di dosare esattamente il ripieno al centro
- . troffie liguri, orecchiette pugliesi, cavatelli, strozzapreti

Italia nasce con l'accessorio estrusore nella configurazione base ed è disponibile il modello su colonna e quello da banco.

Ha una capacità produttiva in funzione del formato della pasta che va dagli 8 Kg/h ai 18 Kg/h.

Inoltre grazie all'impastatrice speciale brevettata "turbomix", permette di accorciare il tempo di preparazione dell'impasto (10 minuti contro i 15 abituali), garantendone comunque l'integrità e l'omogeneità tipiche degli impasti prodotti artigianalmente.

Il design innovativo e il funzionamento semplice ed intuitivo fanno d'Italia la soluzione vincente per le vostre esigenze.



MODELLO DA BANCO - BREVETTATO
TABLE-TOP MODEL - PATENTED
MODÈLE DE TABLE - BREVÉTÉ



IMPASTATRICE "TURBOMIX" BREVETTATA
PATENTED MIXER "TURBOMIX"
PÉTRISSEUSE BREVÉTÉE "TURBOMIX"



ENG Italia, the new automatic multi-purpose fresh-pasta making machine, especially designed for restaurants and hotels, with special press-fit extra accessories, has been developed thanks to the Dominioni Group experience:

- . 400 types of bronze or Teflon - extruded noodles or small-size pasta
- . Smooth or rough pasta sheets with adjustable-thickness
- . Flat noodles
- . Ravioli with soft, creamy or chopped filling, perfectly dosed in the middle
- . Typical regional product such as troffie, orecchiette, cavatelli, strozzapreti

In its base model Italia features the extruder. It is available in the column or table-top version. The machine has an output: from 8 Kg/h to 18 Kg/h depending on the pasta size.

Thanks to the special patented mixer "turbomix", the dough processing time can be shortened (10 minutes, vs. the usual 15 minutes), while maintaining the typical homogeneous texture of artisanal products.

Italia is the winning solution to meet your needs, thanks to its innovative design and user-friendly operating features.

FRA Italia est née de l'expérience de Dominioni Group. Cette nouvelle machine multifonction, conçue pour les restaurants, les hôtels, les traiteurs, est en mesure de produire des pâtes fraîches, lisses ou farcies, en mode automatique grâce aux différents accessoires connectables au groupe principal:

- . 400 types de pâtes courtes ou longues extrudées au moyen de filières bronze ou munies d'inserts en téflon
- . pâtes laminées à épaisseur réglable lisses ou rugueuses
- . pâtes longues plates
- . raviolis à farce souple, crémeuse ou en morceaux, avec possibilité de doser avec précision l'injection de la farce
- . troffie ligures, orecchiette des Pouilles, cavatelli, strozzapreti

Sous sa configuration de base, modèle sur colonne ou de table, Italia est constituéé par une extrudeuse. Sa capacité de production varie, en fonction du format des pâtes, de 8 Kg/h à 18 Kg/h.

La cuve de pétrissage est dotée d'un système breveté "turbomix", qui permet de réduire le temps de préparation de la pâte (de 15 à 10 min), de garantir un mélange parfaitement homogène et de préserver l'intégrité des ingrédients, pour donner au produit fini, l'aspect et le goût typique des pâtes artisanales.

Le design innovateur et le fonctionnement simple et intuitif font d'Italia la solution gagnante pour vos exigences.



MODELLO A COLONNA
COLUMN MODEL . MODÈLE SUR COLONNE

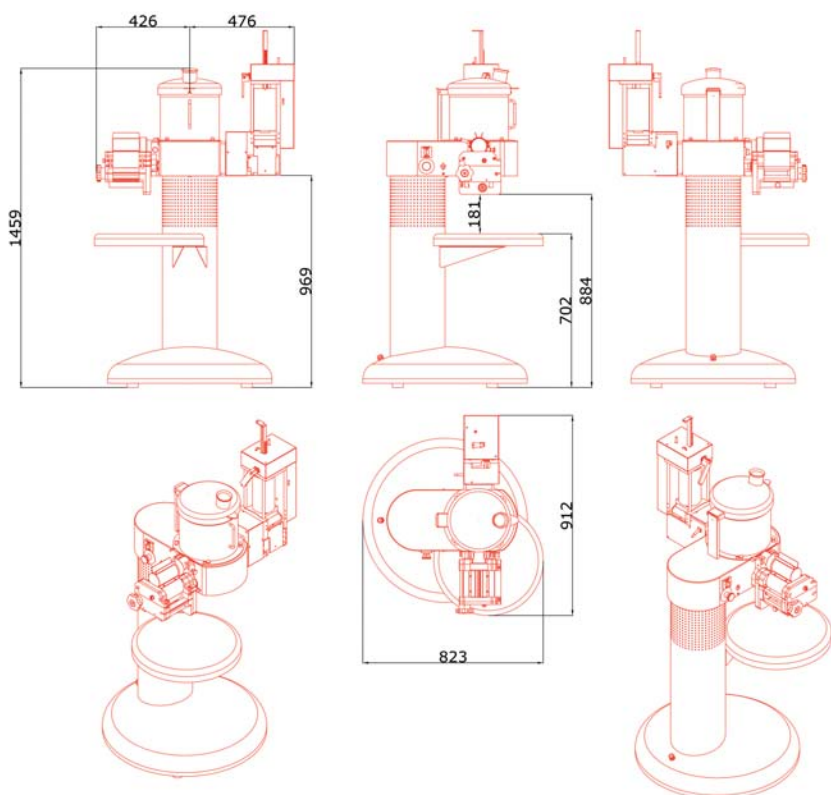

MODELLO DA BANCO
TABLE-TOP MODEL . MODÈLE DE TABLE

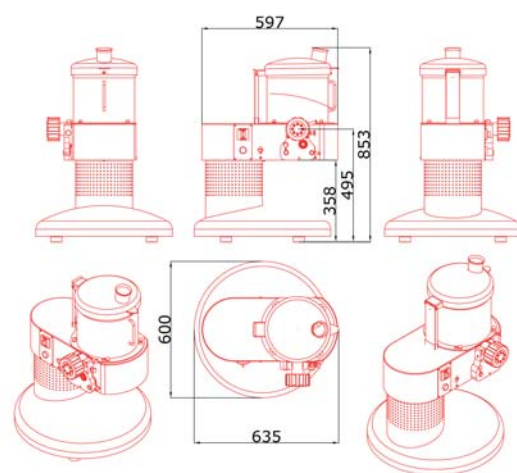

Italia

THE NEW ITALIAN PASTA STYLE



Italia

THE NEW ITALIAN PASTA STYLE



BREVETTATO
PATENTED . BREVETÉ

MODELLO A COLONNA
COLUMN MODEL . MODÈLE SUR COLONNE

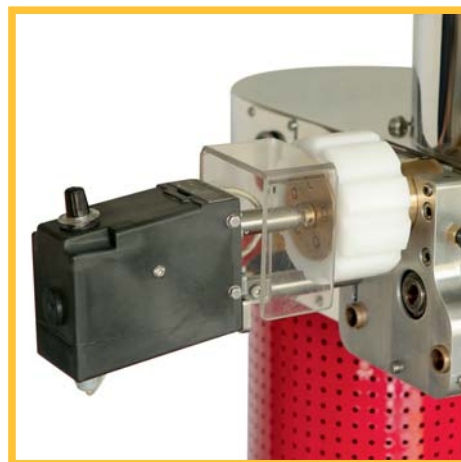
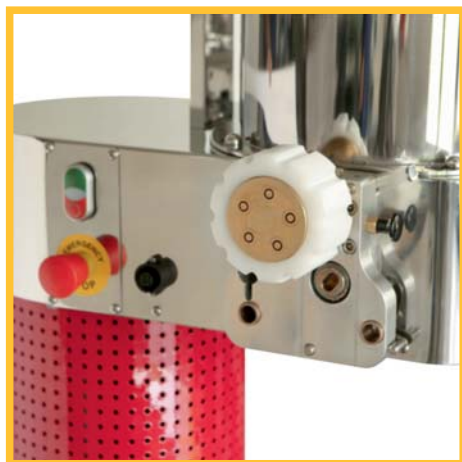

ESTRUSORE

ITA Con questo accessorio è possibile creare 400 tipi di pasta corta e lunga trafilata al bronzo o al teflon.

EXTRUDER . EXTRUDEUSE







ENG 400 types of bronze or Teflon die - cut noodles or small size pasta can be created thanks to this accessory.

FRA Cet accessoire permet de créer 400 types de pâtes courtes et longues tréfilées au bronze ou au téflon.





TRAFILE Ø75

N.B.: le misure indicate sono riferite alle dimensioni sulla trafila.

SPAGHETTI

| | |
|--|-------------------|
|  | • n° 4 0,9 mm BT |
|  | • n° 7 1,5 mm BT |
|  | • n° 9 1,9 mm BT |
|  | • n° 12 2,5 mm BT |
|  | • n° 13 3 mm BT |
|  | • n° 15 4 mm BT |

TAGLIATELLE PAPPARDELLE

| | |
|--|-----------------|
|  | n° 31 2,5 mm BT |
|  | n° 34 6 mm BT |
|  | n° 36 10 mm BT |
|  | n° 38 15 mm BT |



LINGUINE

| | |
|--|-------------------|
|  | n° 21 3x1,6 mm BT |
|  | n° 22 4x1,6 mm BT |

SPAGHETTI GHITARRA

| | |
|--|-----------------|
|  | n° 25 1,8 mm BT |
|  | n° 26 2,5 mm BT |

MAFALDINE

| | |
|--|----------------|
|  | n° 55 12 mm BT |
|  | n° 56 16 mm BT |

FREGOLA







n° 285 B

MACCHERONI LISCI

| | | | |
|--|-------|------|----|
|  | n° 61 | 3 mm | BT |
|  | n° 63 | 6 mm | BT |
|  | n° 64 | 8 mm | BT |



MACCHERONI RIGATI

| | | | |
|--|-------|-------|----|
|  | n° 75 | 3 mm | BT |
|  | n° 76 | 6 mm | BT |
|  | n° 78 | 10 mm | BT |
|  | n° 80 | 15 mm | B |

MACCHERONI CURVI

| | | | |
|--|--------|--------|----|
|  | n° 91 | 3 mm | BT |
|  | n° 102 | 16 mm | B |
|  | n° 122 | 6 mm | BT |
|  | n° 132 | 8,6 mm | BT |
|  | n° 144 | 8,6 mm | BT |

FUSILLI

| | | | |
|--|--------|--------|----|
|  | n° 220 | 8,8 mm | B |
|  | n° 241 | 9,8 mm | BT |
|  | n° 231 | 10 mm | BT |

TROTTOLE

| | | | |
|---|--------|---------|----|
|  | n° 251 | 10,4 mm | BT |
|  | n° 252 | 11,4 mm | BT |

GARGANELLO

| | | | |
|--|--------|--------|---|
|  | n° 267 | 8,3 mm | B |
|--|--------|--------|---|

GNOCCO SARDO

| | | | |
|--|--------|-------|---|
|  | n° 191 | 19 mm | B |
|--|--------|-------|---|

PASTINE

| | | | |
|--|--------|-----------|----|
|  | n° 305 | 6,5x2,1mm | BT |
|  | n° 326 | 6,5 mm | B |
|  | n° 330 | 5,5 mm | B |

RADIATORI

| | | | |
|--|--------|---------|---|
|  | n° 260 | 17,5 mm | B |
|--|--------|---------|---|

RUOTINA

| | | | |
|---|--------|---------|---|
|  | n° 270 | 16,5 mm | B |
|---|--------|---------|---|

Legenda:
B= BRONZO T=TEFLON

Legend:
B= BRONZE T=TEFLON

Légende:
B= BRONZE T=TÉFLON

ACCESSORI EXTRA

EXTRA ACCESSORIES . ACCESSOIRES SUPPLÉMENTAIRES



SFOGLIATRICE

ITA Questa applicazione brevettata permette di passare dalla lavorazione in estrusione alla laminazione con un semplice accessorio gramolatore/laminatoio, garantendo quindi una qualità di sfoglia eccelsa secondo la tradizione pastaia.

Sarà possibile scegliere se ottenere una sfoglia ruvida o tradizionale. L'accessorio prevede la predisposizione a produrre tagliatelle e/o differenti formati di paste lunghe, con spessore regolabile.

PASTA SHEETER LAMINOIR

ENG Thanks to this patented application, by installing the kneading/dough sheeting accessory, you can change from extrusion to lamination to obtain excellent pasta sheets. Rough or smooth texture can be chosen. The accessory can also be set to produce tagliatelle and / or several noodle sizes, with adjustable thickness.

FRA Cette application brevetée permet de passer du travail en extrusion au laminage à l'aide d'un simple accessoire malaxeur/laminoir et de garantir ainsi une excellente qualité d'abaisse, selon la tradition des fabricants de pâtes alimentaires. On pourra choisir une abaisse rugueuse ou traditionnelle. L'accessoire permet également de produire des tagliatelle et/ou différents formats de pâtes longues et de régler leur épaisseur.

FORMATI

SFOGLIA LISCIA



SPECIAL SIZE . FORMAT SPÉCIAL

SMOOTH . LISSE

COD. SFO. A

SFOGLIA RUVIDA



ROUGH . RUSTIQUE

COD. SFO. B

TAGLIOLINO



n° 001 2 mm

TAGLIATELLA



n° 002 4 mm

TAGLIATELLA



n° 003 6 mm

PAPPARDELLA



n° 004 11 mm

Disponibile anche senza greca
Available also with flat edge . Disponible aussi sans zigzag

ACCESSORI EXTRA

EXTRA ACCESSORIES . ACCESSOIRES SUPPLÉMENTAIRES



RAVIOLATRICE DOPPIA SFOGLIA

ITA Questa applicazione brevettata permette di produrre ravioli a doppia sfoglia con la possibilità di intercambiare i formati. Predisposta per la lavorazione di ripieni particolarmente morbidi con possibilità di regolazione della quantità di ripieno e spessore della sfoglia.



DOUBLE-SHEET RAVIOLI MAKER RAVIOLATRICE À DOUBLE ABAISSE

ENG Thanks to this patented application, double dough - sheet ravioli of different sizes can be obtained. It can also work with very soft fillings; the dough sheet thickness and the filling quantity are adjustable.

FRA Cette application brevetée permet de produire des raviolis à double abaisse avec la possibilité de changer de formats. Elle est conçue pour accepter des farces particulièrement souples et un dispositif de réglage assure un dosage précis à l'intérieur des ravioli.

FORMATI

SPECIAL SIZE . FORMAT SPÉCIAL

N° 69

N° 55



N° 12



N° 16



N° 65



N° 74



N° 26



N° 77



N° 62

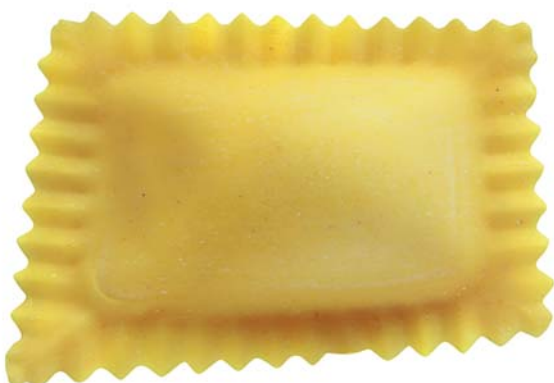

N° 29



N° 3



N° 5



N° 52



N° 115



N° 114



ACCESSORI EXTRA

EXTRA ACCESSORIES . ACCESSOIRES SUPPLÉMENTAIRES



GNOCCATRICE

POTATO GNOCCHI MAKER
MACHINE À GNOCCHIS

ITA

Questa applicazione brevettata permette di produrre gnocchi di patate freschi lisci o rigati di differenti dimensioni.

ENG

Thanks to this application, fresh smooth or grooved gnocchi of different sizes can be produced.

FRA

Cette application brevetée permet de produire des gnocchis de pommes de terre frais lisses ou rayés de différentes tailles.

FORMATI

SPECIAL SIZE . FORMAT SPÉCIAL

RIGATI

LISCI



SCHEDA TECNICA

TECHNICAL DATA . FICHE TECHNIQUE

MODELLO A COLONNA

COLUMN MODEL . MODÈLE SUR COLONNE

PESO
WEIGHT . POIDS

Kg 120

DIMENSIONI
DIMENSIONS . DIMENSIONS

mm 750 x 800 x 1500

MOTORE
MOTORE . MOTEUR

Hp 0,75 KW - 220 VOLT - 50 HZ

IMPASTATRICE
KNEADING MACHINE . PÉTRISSEUSE

CAPACITÀ VASCA
MIXING TANK CAPACITY . CAPACITÉ CUVE

4 Kg + umidità
4 Kg + LIQUIDS . 4 Kg + HUMIDITÉ

COLORI
COLOURS . COLORIS

ROSSO METALLIZZATO
METALIZED RED . ROUGE MÉTALLISÉ



AVORIO METALLIZZATO
METALIZED CREAM . IVOIRE MÉTALLISÉ



BLU METALLIZZATO
METALIZED BLUE . BLEU MÉTALLISÉ



NERO METALLIZZATO
METALIZED BLACK . NOIR MÉTALLISÉ



ACCESSORI EXTRA

EXTRA ACCESSORIES . ACCESSOIRES SUPPLÉMENTAIRES

SFOGLIATRICE

PASTA SHEETER . LAMINOIR

PESO
WEIGHT . POIDS

13 Kg

DIMENSIONI
DIMENSIONS . DIMENSIONS

mm 300 x 200 x 300

PRODUZIONE
PRODUCTION . PRODUCTION

~ 12 Kg/h *

RAVIOLATRICE DOPPIA SFOGLIA

DOUBLE-SHEET RAVIOLI MAKER . RAVIOLATRICE À DOUBLE ABAISSE

PESO
WEIGHT . POIDS

20 Kg

DIMENSIONI
DIMENSIONS . DIMENSIONS

mm 180 x 150 x 380

PRODUZIONE
PRODUCTION . PRODUCTION

~ 18 Kg/h **

GNOCCATRICE

POTATO GNOCCHI MAKER . MACHINE À GNOCCHIS

PESO
WEIGHT . POIDS

5 Kg

DIMENSIONI
DIMENSIONS . DIMENSIONS

mm 150 x 140 x 160

PRODUZIONE
PRODUCTION . PRODUCTION

8 Kg/h

TROFFIATRICE ***

TROFFIE MAKER . MACHINE A TROFFIE

PESO
WEIGHT . POIDS

3,5 Kg

DIMENSIONI
DIMENSIONS . DIMENSIONS

mm 150 x 140 x 160

PRODUZIONE
PRODUCTION . PRODUCTION

8 Kg/h

FRUSTA PASTA DI PANE E PIZZA ***

BEATER FOR PIZZA AND BREAD . FOUET DE PÂTE POUR PAIN ET PIZZA

PESO
WEIGHT . POIDS

1,5 Kg

PRODUZIONE
PRODUCTION . PRODUCTION

12 Kg/h

* Dipende dallo spessore della sfoglia
It depends on sheet thickness . Selon l'épaisseur de l'abaisse

** Dipende dalla quantità di ripieno
It depends on the filling quantity . Selon la quantité de farce

*** Accessori non ancora disponibili
Accessories not available, yet . Accessoires non encore disponibles

Passioni di bufala

CON POMODORI CUORI DI BUE, SAUSA AL BASILICO
E PINOLI TOSTATI



ITA

INGREDIENTI DELLA SFOGLIA:

1 kg di semola di grano duro - 8 uova

INGREDIENTI DEL RIPIENO:

400 gr di mozzarella di bufala ben scolata

1 uovo intero - 50 gr grana padano

10 gr sale bilanciato - 1 gr pepe nero

1 gr noce moscata

INGREDIENTI DI ESECUZIONE:

100 gr basilico fresco - 50 gr olio d'oliva extra vergine

10 gr di pinoli - 2 gr sale

PROCEDIMENTO:

Impastare e tirare la sfoglia con la macchina Italia.
Amalgamare tutti gli ingredienti del ripieno e lasciarli riposare
in frigo per ca 1h.

Confezionare i ravioli con l'apposito stampo

COMPOSIZIONE DEL PIATTO:

Affettare il più sottilmente possibile i pomodori
cuori di bue.

Creare un fondo sul piatto.

Adagiarvi sopra 3 ravioloni.

Condirli con una crema al basilico e guarnire con pinoli tostati.

ENG 'PASSIONI' WITH BUFFALO MOZZARELLA CHEESE, "CUORE DI BUE" TOMATOES, BASIL SAUCE AND ROASTED PINE KERNELS

INGREDIENTS FOR THE PASTA SHEET:

1 kg of durum wheat bran - 8 eggs

INGREDIENTS FOR THE FILLING:

400 g of well drained buffalo mozzarella cheese

1 egg (both white and yolk) - 50 g grana cheese

10 g salt and sugar mix - 1 g black pepper - 1 g nutmeg

INGREDIENTS FOR THE MAKING:

100 g fresh basil - 50 g extra-virgin olive oil

10 g pine kernels - 2 g salt

HOW TO PROCEED:

Knead the dough and roll out the pasta sheet using the machine Italia.

Mix all the ingredients for the filling and let rest in the fridge for about 1 hour.

Make the ravioli using the appropriate die.

PREPARING THE DISH

Slice the "cuore di bue" tomatoes as thin as possible.

Arrange the slices in a layer over the dish.

Place 3 big ravioli on top.

Dress with basil cream and garnish with roasted pine kernels.

FRA

MOZZARELLA DE BUFFLE AVEC TOMATES "CŒUR DE BOEUF", SAUCE AU BASILIQUE ET PIGNONS GRILLÉS

INGRÉDIENTS DE L'ABAISSE:

1 kg de semoule de grain dur - 8 oeufs

INGRÉDIENTS DE LA FARCE:

400 g de mozzarella de buffle bien égouttée - 1 œuf entier - 50 g de grana padano

10 g de sel équilibré - 1 g de poivre noir - 1 g de noix muscade

INGRÉDIENTS D'EXÉCUTION:

100 g de basilique frais - 50 g d'huile d'olive vierge extra

10 g de pignons - 2 g de sel

PROCÉDURE:

Pétrir et tirer l'abaisse avec la machine Italia.

Amalgamer tous les ingrédients de la farce et les laisser reposer au réfrigérateur pendant environ 1 heure.

Préparer les raviolis dans le moule.

COMPOSITION DE L'ASSIETTE:

Couper finement les tomates "cœur de boeuf".

Créer un fond dans l'assiette.

Poser 3 gros raviolis.

Les assaisonner d'une crème au basilique et les garnir des pignons grillés.

Fatti a mano

RIPIENI AL RAGU DI SCORFANO ADAGIATI SOPRA UN VELO DI ZUCCHINA GIALLA E NUVOLE DI RICOTTA SALATA DI PECORA

ITA

INGREDIENTI DELLA SFOGLIA:

1 kg di semola di grano duro - 8 uova

INGREDIENTI DEL RIPIENO:

1 kg scorfano - 100 gr pomodori Pachino
100 gr di vino bianco secco - 50 gr olio d'oliva extra vergine
30 gr sale bilanciato per pesce - 10 gr rosmarino fresco
6 gr aglio fresco

INGREDIENTI DI ESECUZIONE:

2 zucchine gialle - 100 gr pomodoro Ramato (concassé)
50 gr burro - 50 gr pecorino Romano - 20 gr parmigiano
10 gr sale - ricotta salata di pecora

PROCEDIMENTO:

Impastare e tirare la sfoglia con la macchina Italia.
Cucinare lo scorfano al forno con tutti gli ingredienti per ca 40 min pulirlo, spinarlo bene e amalgamare la polpa ed il resto degli ingredienti.
Aggiungere 50 gr di pecorino Romano.
Regolare di sale e pepe e lasciare riposare 1h in frigo.
Confezionare i ravioli con l'apposito stampo

COMPOSIZIONE DEL PIATTO:

Preparare una crema di zucchine e napparci il piatto.
Adagiarvi sopra 2 ravioloni.
Guarnirli con una concassé di pomodoro e delle nuvole di ricotta salata di pecora.



ENG

"HAND-MADE" RAVIOLI FILLED WITH SCORPION FISH RAGOUT ARRANGED OVER A LAYER OF YELLOW COURGETTES WITH CLOUDS OF SALTED SHEEP'S RICOTTA CHEESE

INGREDIENTS FOR THE PASTA SHEET:

1 kg durum wheat bran - 8 eggs

INGREDIENTS FOR THE FILLING:

1 kg scorpion fish - 100 g Pachino tomatoes - 100 g dry white wine - 50 g extra-virgin olive oil - 30 g salt and sugar mix special for fish dishes - 10 g fresh rosemary - 6 g fresh garlic

INGREDIENTS FOR THE MAKING:

2 yellow courgettes - 100 g vine tomatoes (concassé)
50 g butter - 50 g pecorino romano cheese - 20 g parmesan cheese - 10 g salt salted sheep's ricotta cheese

HOW TO PROCEED:

Knead the dough and roll out the pasta sheet using the machine Italia. Bake the scorpion fish in the oven with all the ingredients for about 40 minutes. Carefully remove all the bones from the scorpion fish, then amalgamate the fish meat obtained with the remaining ingredients. Add 50 g of pecorino romano cheese. Add salt and pepper as required and let rest in the fridge for about 1 hour. Make the ravioli using the appropriate die.

PREPARING THE DISH:

Make a creamy sauce with the courgettes, and spread over the dish. Place 2 ravioli over the layer of courgette sauce. Garnish with tomato concassé and clouds of salted sheep's ricotta cheese.

FRA

RAVIOLIS FAITS À LA MAINS, FARCIS AU RAGOÛT DE SÉBASTE COUCHÉS SUR UN LIT DE COURGETTE JAUNE ET RECOUVERTS DE NUAGES DE RICOTTA SALÉE DE CHÈVRE.

INGRÉDIENTS DE L'ABAISSE:

1 kg de semoule de grain dur - 8 oeufs

Ingrédients de la farce:

1 kg de sébaste - 100 g de tomates Pachino
100 g de vin blanc sec - 50 g d'huile d'olive vierge extra
30 g de sel équilibré pour poisson - 10 g de romarin frais
6 g d'ail frais

INGRÉDIENTS D'EXÉCUTION:

2 courgettes jaunes - 100 g de tomates Ramato (concassé)
50 g de beurre - 50 g de pecorino Romain
20 g de parmesan - 10 g de sel ricotta salée de chèvre

PROCÉDURE:

Pétrir et tirer l'abaisse avec la machine Italia.
Faire cuire le sébaste au four avec tous les ingrédients pendant environ 40 min. Ensuite le nettoyer, enlever les arêtes et amalgamer la chair au reste des ingrédients.
Ajouter 50 gr de pecorino Romain.
Saler et poivrer puis laisser reposer au réfrigérateur pendant 1 heure. Préparer les raviolis dans le moule.

COMPOSITION DE L'ASSIETTE:

Préparer une crème de courgettes et l'étendre sur l'assiette.
Poser 2 gros raviolis. Les garnir d'un concassé de tomates et de nuages de ricotta salée de chèvre.

DOMINIONI GROUP

WORLD FAMOUS PASTA MACHINES

DOMINIONI PUNTO & PASTA s.a.s.

Via Repubblica, 8/A - 22075 Lurate Caccivio (CO) ITALY - Tel. +39 031 490 457 - Fax +39 031 390 110 - 231

info@dominioni-puntoepasta.com - www.dominioni.it

ITALIA IS CERTIFIED

